

USER'S MANUAL  
BEDIENUNGSANLEITUNG  
MANUEL D'UTILISATION  
MANUAL DE USUARIO  
INSTRUKCJA OBSŁUGI  
MANUALE D'USO

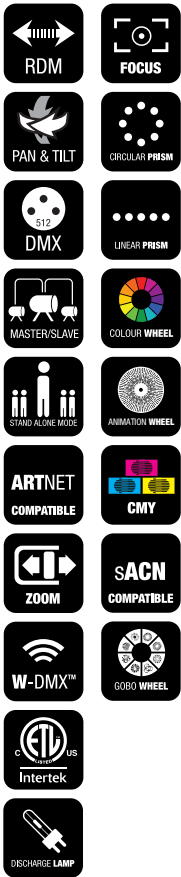

# OPUS H5

BEAM SPOT WASH HYBRID MOVING HEAD  
CLOH5

# CONTENTS / INHALTSVERZEICHNIS / CONTENU / CONTENIDO / TREŚĆ / CONTENUTO

## ENGLISH

SAFETY INFORMATION	3
INTRODUCTION	5
CONNECTIONS, OPERATING AND DISPLAY ELEMENTS OPERATION	8
W-DMX™	10
W-DMX™ STATUS	10
CONTROL MENU (Control)	11
SYSTEM SETTINGS (Settings)	15
DEVICE INFORMATION (Info)	17
SERVICE MENU (Service)	18
QUICKLIGHT	19
HELP MENU (Help)	19
INSTALLATION AND MOUNTING	20
REPLACING THE LAMP	20
CALIBRATING THE LAMP	22
DMX TECHNOLOGY	23
TECHNICAL DATA	24
MANUFACTURER'S DECLARATIONS	25

## DEUTSCH

SICHERHEITSHINWEISE	26
EINFÜHRUNG	28
ANSCHLÜSSE, BEDIEN- UND ANZEIGEELEMENTE BEDIENUNG	31
W-DMX™	33
W-DMX™ STATUS	33
KONTROLLMENÜ (Control)	34
SYSTEMEINSTELLUNGEN (Settings)	38
GERÄTEINFORMATIONEN (Info)	40
SERVICE-MENÜ (Service)	41
QUICKLIGHT	42
HILFMENÜ (Help)	42
AUFSTELLUNG UND MONTAGE	43
AUSTAUSCHEN DES LEUCHTMITTELS	43
JUSTIEREN DES LEUCHTMITTELS	45
DMX TECHNIK	46
TECHNISCHE DATEN	47
HERSTELLERERKLÄRUNGEN	48

## FRANCAIS

MESURES PRÉVENTIVES	49
INTRODUCTION	51
RACCORDEMENTS, ÉLÉMENTS DE COMMANDE ET D'AFFICHAGE	51
MODE D'EMPLOI	54
W-DMX™	56
ÉTAT W-DMX™	56
PANNEAU DE COMMANDE (Control)	57
PARAMÈTRES DU SYSTÈME (Settings)	61
INFORMATIONS SUR L'APPAREIL (Info)	63
MENU DE SERVICE (Service)	64
QUICKLIGHT	65
MENU D'AIDE (Help)	65
INSTALLATION ET MONTAGE	66
REMPLACEMENT DE LA LAMPE	66
RÉGLAGE DE LA LAMPE	68
TECHNIQUE DMX	69
CARACTÉRISTIQUES TECHNIQUES	70
DECLARATIONS	71

## ESPAÑOL

MEDIDAS DE SEGURIDAD	72
INTRODUCCIÓN	74
CONEXIONES, ELEMENTOS DE MANEJO Y ELEMENTOS DE VISUALIZACIÓN	74
MANEJO	77
W-DMX™	79
ESTADO W-DMX™	79
MENÚ DE CONTROL (Control)	80
CONFIGURACIÓN DEL SISTEMA (Settings)	84
INFORMACIÓN DEL EQUIPO (Info)	86
MENÚ DE SERVICIO (Service)	87
QUICKLIGHT	88
MENÚ DE AYUDA (Help)	88
INSTALACIÓN Y MONTAJE	89
CAMBIO DE LA LÁMPARA	89
AJUSTE DE LA LÁMPARA	91
TECNOLOGÍA DMX	92
DATOS TÉCNICOS	93
DECLARACIÓN DEL FABRICANTE	94

## POLSKI

ŚRODKI OSTROŻNOŚCI	95
WPROWADZENIE	97
PRZYŁĄCZA, ELEMENTY STERUJĄCE I WSKAŹNIKI	97
OBŚŁUGA	100
W-DMX™	102
STATUS W-DMX™	102
MENU STEROWANIA (Control)	103
USTAWIENIA SYSTEMU (Settings)	107
INFORMACJE O URZĄDZENIU (Info)	109
MENU SERWISOWE (Service)	110
QUICKLIGHT	111
MENU POMOCY (Help)	111
USTAWIANIE I MONTAŻ	112
WYMIANA ŹRÓDŁA ŚWIATŁA	112
REGULACJA ŹRÓDŁA ŚWIATŁA	114
TECHNIKA DMX	115
DANE TECHNICZNE	116
DEKLARACJE PRODUCENTA	117

## ITALIANO

MISURE PRECAUZIONALI	118
INTRODUZIONE	120
CONNESSIONI, ELEMENTI DI COMANDO E DI VISUALIZZAZIONE	120
UTILIZZO	123
W-DMX™	125
STATO W-DMX™	125
MENU DI CONTROLLO (Control)	126
IMPOSTAZIONI DI SISTEMA (Settings)	130
INFORMAZIONI SUL DISPOSITIVO (Info)	132
MENU ASSISTENZA (Service)	133
QUICKLIGHT	134
MENU GUIDA (Help)	134
INSTALLAZIONE E MONTAGGIO	135
SOSTITUZIONE DELLA LAMPADA	135
REGOLAZIONE DELLA LAMPADA	137
TECNOLOGIA DMX	138
DATI TECNICI	139
DICHIARAZIONI DEL PRODUTTORE	140

## DMX

DMX CONTROL / DMX STEUERUNG / PILOTAGE DMX / CONTROL DMX / STEROWANIE DMX / CONTROLLO DMX	141
---	-----

**YOU HAVE MADE THE RIGHT CHOICE!**

This device was developed and produced under the highest standards of quality in order to ensure smooth operation for many years. Please read these operating instructions carefully so that you can use your new Cameo Light product quickly and optimally. You can find more information on Cameo Light on our website [WWW.CAMEOLIGHT.COM](http://WWW.CAMEOLIGHT.COM).

**SAFETY INFORMATION**

1. Please read through these instructions carefully.
2. Store all information and instructions in a secure location.
3. Follow the instructions.
4. Heed all warnings. Do not remove any safety warnings or other information from the device.
5. Use the device only in the intended manner.
6. Use only stable and suitable stands and/or mounts (for fixed installations). Make sure that wall mounts are properly installed and secured. Make sure that the device is securely installed and will not fall.
7. During installation, heed all safety provisions that apply in your country.
8. Do not install and operate the device in the vicinity of heaters, heat reservoirs, ovens, or other heat sources. Make sure that the device is installed in such a way that it is sufficiently cooled and will not overheat.
9. Do not place any ignition sources, e.g. candles, on the device.
10. Do not block the ventilation slits.
11. The device was designed to be used only in interior spaces, do not operate the device in the direct vicinity of water (this does not apply to specialty outdoor devices - in this case, please note the special instructions given in the following). Do not bring the device into contact with combustible materials, fluids, or gases.
12. Make sure that no water can drop or splash into the device. Do not place any containers filled with fluids, such as vases or drinking vessels, onto the device.
13. Ensure that no objects can fall into the device.
14. Operative the device using only those accessories recommended and specified by the manufacturer.
15. Do not open the device, and do not modify it.
16. After connecting the device, inspect all cable paths in order to avoid damage or accidents, such as those caused by tripping over said cables.
17. During transport, ensure that the device will not fall and potentially cause material damage and personal harm.
18. If your device no longer functions properly, fluids or objects have made their way into the device interior, or the device is otherwise damaged, switch it off immediately and remove it from the power outlet (provided the device is active).  
This device is to be repaired only by authorized specialists.
19. Use a dry towel to clean the device.
20. Follow all laws on disposal applicable in your country. Please separate plastic and paper or cardboard when disposing of the packaging.
21. Plastic bags must be kept out of reach of children.

**FOR DEVICES CONNECTED TO A POWER SUPPLY:**

22. **ATTENTION:** If the device power cable is equipped with a ground pin, it must be inserted into an outlet with a grounding conductor. Never disable the grounding conductor of a power cable.
23. Do not immediately switch on the device when it has been exposed to stark temperature deviations (for example after transport). Humidity and condensation could damage the device. Switch on the device only when it has reached room temperature.
24. Before you connect the device to the outlet, first ensure that voltage and frequency of the power supply complies with the values given on the device. If the device has a voltage selector switch, connect the device to the outlet only if the device values comply with the values of the power supply. If the provided power cable or power adapter does not fit your power outlet, contact an electrician.
25. Do not step on the power cable. Make sure that live cables, in particular those at the power socket or at the power adapter and the device socket, are not bent.
26. With regard to the device cables, always make sure that the power cable or power adapter is always freely accessible. Always separate the device from the power supply when the device is not in use or when you would like to clean the device. Always unplug the power cable and power adapter from the power outlet using the plug or adapter, not the cord. Never touch the power cable and power adapter with wet hands.
27. If possible, do not switch the device on and off quickly because this may impair the service life of the device.
28. **IMPORTANT INFO:** Replace fuses only with fuses of the same type and value. If a fuse trips repeatedly, please contact an authorized service center.
29. In order to completely separate the device from the power supply, remove the power cable or power adapter from the outlet.
30. If your device is equipped with a Volex power cord, release the correct Volex device connector before removing the cord. However, this also means that the device may slide and fall when removing the power cord, which may cause personal harm and/or material damage. Therefore, always lay cables carefully.
31. Remove the power cable and power adapter from the outlet when there is a risk of lighting or when you no longer want to use the device.
32. The device may only be installed when it carries no voltage (separate the power plug from the power supply).
33. Dust and other debris within the device may damage it. The device should be serviced or cleaned regularly by qualified specialists depending on the environmental conditions (dust, nicotine, smoke, etc.) in order to avoid overheating.
34. The distance to combustible materials must be at least 0.5 m.
35. Power cables for powering multiple devices must have a core cross-section of at least 1.5 mm<sup>2</sup>. In the EU, lines must be H05VV-F or similar. Adam Hall provides suitable cables. Using these cables, you can connect multiple devices via the Power Out connection with the Power In connection of another device. Ensure that the total power consumption of all connected devices does not exceed the specified value (printed on the device). Be sure to keep power lines as short as possible.

36. The appliance is not to be used by persons (including children) with reduced physical, sensory or mental capabilities, or lack of experience and knowledge.
37. Children must be instructed not to play with the device.
38. If the power cord of the device is damaged, do not use the device. The power cord must be replaced by an adequate cable or assembly from an authorized service center.

**CAUTION:**

To reduce the risk of electric shock, do not remove cover (or back). There are no user serviceable parts inside. Maintenance and repairs should be exclusively carried out by qualified service personnel.



The warning triangle with lightning symbol indicates dangerous uninsulated voltage inside the unit, which may cause an electrical shock.



The warning triangle with exclamation mark indicates important operating and maintenance instructions.



Warning! This symbol indicates a hot surface. Certain parts of the housing can become hot during operation. After use, wait for a cool-down period of at least 10 minutes before handling or transporting the device.



Warning! This device is designed for use below 2000 metres in altitude.



Warning! This product is not intended for use in tropical climates.



Caution! Intense LED light source! Risk of eye damage. Do not look into the light source.

**CAUTION! IMPORTANT INFORMATION ABOUT LIGHTING PRODUCTS!**

1. The product has been developed for professional use in the field of event technology and is not suitable as household lighting.
2. Do not stare, even temporarily, directly into the light beam.
3. Do not look at the beam directly with optical instruments such as magnifiers.
4. Stroboscope effects may cause epileptic seizures in sensitive people! People with epilepsy should definitely avoid places where strobes are used.

## INTRODUCTION

### MOVING HEAD OPUS SERIES

CLOH5

#### CONTROL FUNCTIONS

- 29-channel and 36-channel DMX control
- Art-Net
- sACN
- W-DMX™
- RDM-enabled
- Master/slave operation
- Standalone functions

#### FEATURES

471W Osram discharge lamp, cold white 7500 K. Animation wheel CMY color mix. Color wheel with 13 brilliant colors + open and split colors. 22 gobos on 2 gobo wheels. 2 rotating prisms. Focusing and zoom function can be controlled via DMX. 2 frost filters. Stroboscope effect. Pan and tilt motors with 16-bit resolution. Battery-powered display for mains-free configuration. Temperature-controlled fan. 3- and 5-pin DMX connections. RJ45 network connections. Art-Net and sACN. Wireless DMX™. Neutrik powerCON TRUE1 mains connections IN and OUT. 2 x Omega mounting brackets included. Operating voltage 100–240 V AC. Power consumption 700 W.

The spotlight features the RDM standard (Remote Device Management). Remote Device Management allows the user to view the status and configuration of RDM terminals via an RDM-capable controller.

## CONNECTIONS, OPERATING AND DISPLAY ELEMENTS



#### 1 POWER IN

Neutrik powerCON TRUE1 mains input socket. Operating voltage 100–240 V AC/50–60 Hz. A suitable mains cable with powerCON TRUE1 plug is included.

#### 2 POWER OUT

Neutrik powerCON TRUE1 mains output socket. Facilitates power supply to other CAMEO lights. Ensure that the total power consumption of all devices connected to the device does not exceed the given ampere (A) value.

**3 FUSE**

Fuse holder for 5 x 20 mm micro fuses. **IMPORTANT:** Replace the fuse only with a fuse of the same type and value. In the event of repeated fuse failure, please contact an authorised service centre.

**4 DMX IN**

Male 3-pin and 5-pin XLR sockets for connection to a DMX control device (e.g. DMX console). Only use the ports alternatively.

**5 DMX OUT**

Female 3-pin or 5-pin XLR sockets for sending the DMX control signal. Only use the ports alternatively.

**6 NET IN**

RJ45 network connector for connecting to an Art-Net or sACN network. Use CAT-5e or better cables to set up the network.

**7 NET OUT**

RJ45 network connector for connecting additional Art-Net or sACN-capable devices to the network. Use CAT-5e or better cables to set up the network.

**8 ANTENNE FOR W-DMX™**

The antenna for control via W-DMX™ remains in the holder (= operating position) during operation.

**9 PRESSURE SENSITIVE LC DISPLAY WITH ILLUMINATION**

Thanks to the pressure-sensitive LC display, the device can be operated directly from the display (glove-compatible). The display shows the currently activated mode (main display), the menu items in the main menu and sub-menus and the numerical value or status in certain menu items. If there is no control signal to the device, the display starts flashing; the flashing stops as soon as a control signal is available (W-DMX, DMX and slave operation, ArtNet and sACN).

**10 ROTARY-PUSH ENCODER**

Rotary-push encoder for navigating in the editing menu, adjusting system settings and changing values and status in the corresponding menu items.

Starting from the main display, press the encoder to enter the main menu. Select the individual menu items in the main menu (Control, Settings, Info, etc.) and in the sub-menus by turning the encoder and confirm the selection by pressing the encoder. Change the value or status in a menu item by turning the encoder and confirm the change by pressing the encoder.

**11 BACK**

Briefly press BACK to go up one level in the menu structure. To go directly from the sub-menus to the main display, press and hold the BACK button for about 2 seconds.

## 12 USB INTERFACE

USB interface for updating the device firmware. In the **Service menu**, set the status for **USB Update** to **Yes**. When available, download the latest firmware from the product page at [www.cameolight.com](http://www.cameolight.com), unzip it and copy the files to a folder without special characters on a USB stick. Disconnect the Moving Head from the mains and all input connections (DMX / Ethernet), connect the USB stick to the USB interface and reconnect the Moving Head to the mains. The USB stick is automatically recognized and shown in the display. Now navigate to the corresponding folder on the USB stick and confirm with "ON". The update procedure begins. If updates are required for several components, the procedure must be carried out individually for all updates. Do not remove the USB stick or disconnect the Moving Head from the mains during the update procedure.

## BATTERY-POWERED DISPLAY

The battery-powered display can be activated, even if the device is not connected to the mains. To do this, press and hold the rotary-push encoder for approximately 2 seconds. You can now access device information to change and save system settings without mains connection. The external control of the spotlight is not activated in this case. For this reason, the display shows that there is no DMX signal even if a DMX signal is available at the device.



### 13 PAN LOCK

Mechanical locking device used to prevent the rotation of the head in the horizontal direction during transport. Disconnect the unit from the mains, move the head parallel to the base (8 possible positions) and push the locking lever in the direction of the pan rotation axis (LOCK) to lock it in position. Unlock the device before startup (UNLOCK).



### 14 TILT LOCK

Mechanical locking device used to prevent rotation of the head in the vertical direction during transport (7 possible positions). Disconnect the unit from the mains and slide the locking lever in the direction of the tilt rotation axis, moving the head of the unit vertically until one of the 7 locking positions is found and the locking lever engages (LOCK). Unlock the device before startup (UNLOCK).

### 15 RECESSED GRIPS

In addition to the two transport handles on the base of the unit, there are practical recessed grips at the top of the inner sides of the two device arms.



## OPERATION

### NOTES

When the lamp is correctly connected to the mains supply, the Cameo logo is shown on the display during start-up and motor reset along with details of the device model. After this process, the spotlight is ready for operation and the previously activated operating mode is launched.

The main display is activated automatically after approximately two minutes without input. Press BACK to go up one level in the sub-menus.

In the event of a technical fault, the lamp is switched off, the display shows "Lamp Protected" in red letters and the warning triangle symbol appears in the top right-hand corner (tap for further information).

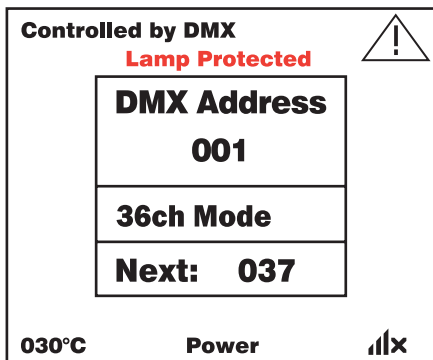

The spotlight is operated firstly by means of the rotary push-pull encoder and the BACK button next to the display, and secondly the pressure-sensitive display (glove-compatible) itself can be used to access all menu items and configure settings intuitively as desired. The control panels in the main display and in the main menu or sub-menus and their functions are shown in the illustrations below. The fields marked grey in the illustration of the main display are control panels with direct access.

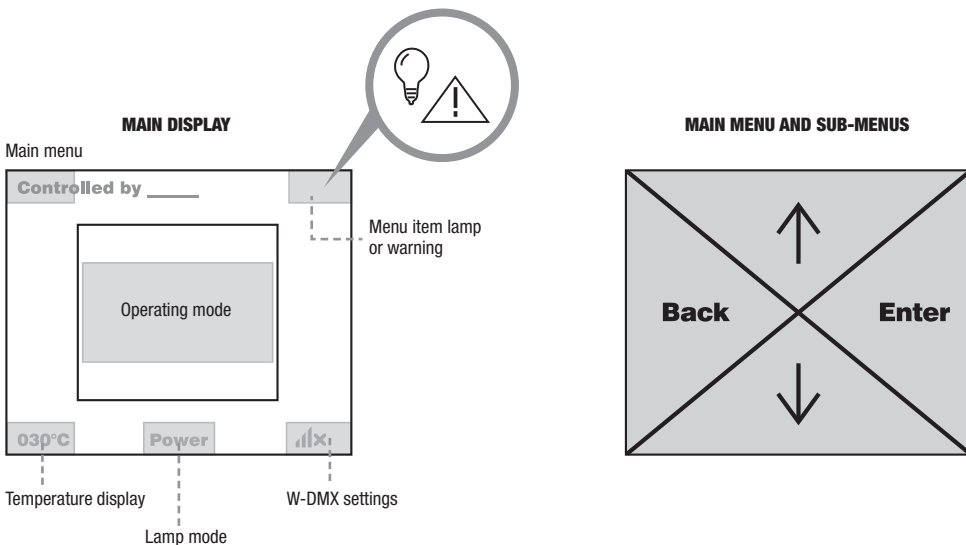



**MAIN DISPLAY DMX AND W-DMX OPERATING MODE**

The top line of the display shows whether a control signal is available at the device, the middle field shows the DMX start address, the DMX mode and the address following the start address set in the device, corresponding to the number of channels of the DMX mode. The bottom line displays the device head temperature, lamp mode and W-DMX status.

As soon as the control signal is interrupted, the characters in the display start flashing and "None" is shown after "Controlled by" in the top line (no signal); when the control signal is available again, the flashing stops.

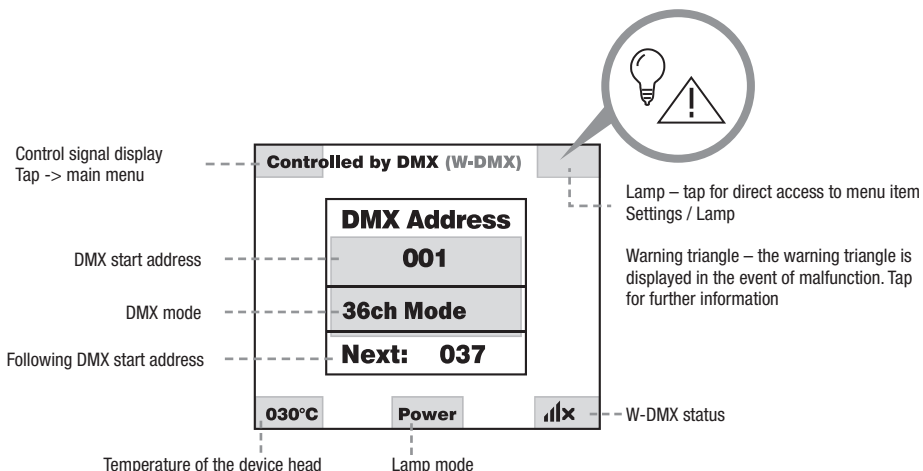

The fields marked grey in the figure are control panels with direct access to the corresponding menu item.

**MAIN DISPLAY ART-NET AND SACN OPERATING MODE**

The top line of the display shows whether a control signal is available at the device, the middle field shows the operating mode, the DMX start address, the DMX mode and the address following the start address set in the device, corresponding to the number of channels of the DMX mode. Below this, the DMX universe, IP address and subnet mask are displayed.

The bottom line displays the device head temperature, lamp mode and W-DMX status. As soon as the control signal is interrupted, the characters in the display start flashing and "None" is shown after "Controlled by" in the top line (no signal); when the control signal is available again, the flashing stops.

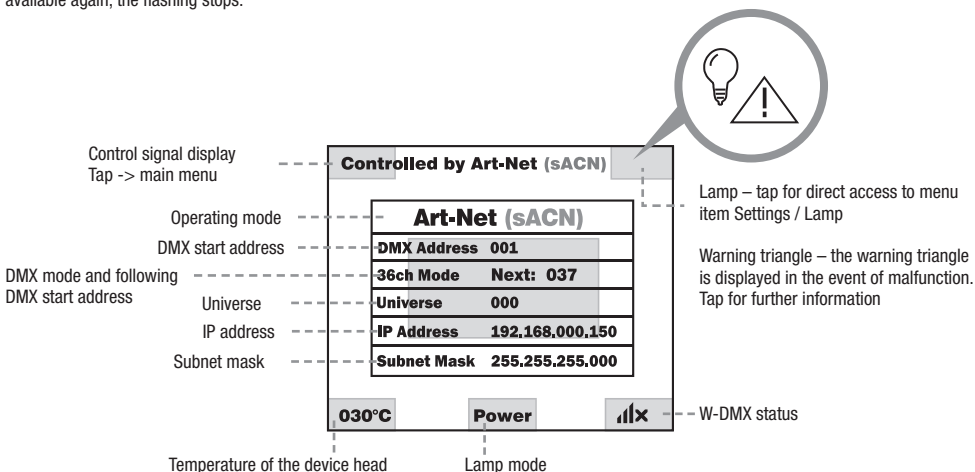

The fields marked grey in the figure are control panels with direct access to the corresponding menu item.

## MAIN DISPLAY SLAVE AND STATIC MODE

The top line of the display shows whether a control signal is available on the device and the middle field shows the SLAVE or STATIC mode with the selected scene (Run Scene x). The bottom line displays the device head temperature, lamp mode and W-DMX status. If the control signal is interrupted in slave mode, the characters in the display start flashing and "None" is shown after "Controlled by" in the top line (no signal); when the control signal is available again, the flashing stops.

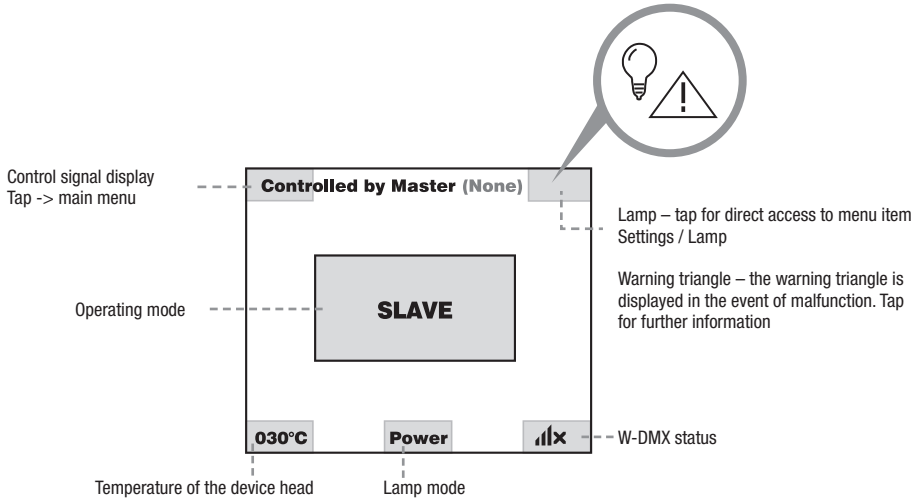

The fields marked grey in the figure are control panels with direct access to the corresponding menu item.

## W-DMX™

To pair a W-DMX receiver with a W-DMX compatible transmitter, the Reset command must be executed in the menu item WDMX under Receiver (select and confirm Reset). The receiver is now in pairing standby and waiting for a pairing request from a transmitter. Start the pairing by selecting Link in the menu of the transmitter and confirming; the pairing now takes place automatically. In the same way, several receivers can be paired simultaneously or one after the other to a transmitter (e.g. for master/slave operation). A W-DMX connection is always maintained until the connection is disconnected by means of the Reset command in the receiver or the Unlink command in the transmitter, regardless of whether a device has been disconnected from the power supply in the meantime.

## W-DMX™ STATUS

W-DMX deactivated	W-DMX activated as receiver, not paired	W-DMX activated as receiver and paired, transmitter is switched off or out of range	W-DMX activated as receiver and paired, no DMX signal	W-DMX activated as receiver and paired, DMX signal available	W-DMX activated as transmitter with G3 standard, DMX signal available	W-DMX activated as transmitter with G4s standard, DMX signal available	W-DMX activated as transmitter with G3 standard, no DMX signal	W-DMX activated as transmitter with G4s standard, no DMX signal

The following is a description of how to operate the spotlight using the rotary-push encoder and the BACK button next to the display.

## CONTROL MENU (Control)

The control menu enables selection of the various operating modes and their settings in the relevant sub-menus.

### DMX OPERATION VIA XLR INPUT

Starting from the main display, press the rotary-push encoder to enter the main menu. Select the **Control** menu by turning the encoder and pressing the encoder. By turning the encoder you can now select the menu item **Protocol**, confirm by pressing the encoder and then select **DMX** by turning the encoder and confirm by pressing the encoder.

<p>..... Menu .....</p> <p>► <b>Control</b></p> <p><b>Settings</b></p> <p><b>Info</b></p> <p><b>Service</b></p> <p><b>Quicklight</b></p> <p><b>Help</b></p>	<p>..... Control .....</p> <p>► <b>Protocol</b> <span style="float: right;"><b>DMX</b></span></p> <p><b>DMX Address</b></p> <p><b>DMX Mode</b></p> <p><b>W-Transmitter</b></p> <p><b>W-DMX Standard</b></p> <div style="border: 1px solid black; padding: 2px; width: fit-content; margin: 5px auto;"> <p>► <b>DMX</b></p> <p><b>WDMX</b></p> <p><b>ArtNet</b></p> <p><b>sACN</b></p> <p><b>Slave</b></p> <p><b>Static</b></p> </div>	<p>..... Control .....</p> <p><b>Protocol</b> <span style="float: right;"><b>DMX</b></span></p> <p>► <b>DMX Address</b> <span style="float: right;"><b>001</b></span></p> <p><b>DMX Mode</b> <span style="float: right;"><b>36ch</b></span></p> <p><b>W-Transmitter</b> <span style="float: right;"><b>On</b></span></p> <p><b>W-DMX Standard</b> <span style="float: right;"><b>G4s</b></span></p>
---	---	---

Information on the sub-menu items in the DMX menu and the relevant setting options are to be found in the table below.

Protocol DMX		
Select by turning the encoder, confirm by pressing, change value or status by turning, confirm by pressing. Back with BACK.		
DMX Address	Setting the DMX start address	001–512
DMX Mode	Selecting the DMX mode	29ch/36ch
W transmitter	Activate (On) or deactivate (Off) forwarding of the DMX signal via W-DMX	On
	Establish (Linking) or release (Unlink) a connection to other W-DMX devices.	Off
		Linking
		Unlink
W-DMX standard	Setting the W-DMX standard (G3 / G4s)	G3
		G4s

### DMX OPERATION VIA W-DMX

Starting from the main display, press the rotary-push encoder to enter the main menu. Select the **Control** menu by turning and pressing the encoder. By turning the encoder you can now select the menu item **Protocol**, confirm by pressing the encoder and then select **WDMX** by turning the encoder and confirm by pressing the encoder.

<p>..... Menu .....</p> <p>► <b>Control</b></p> <p><b>Settings</b></p> <p><b>Info</b></p> <p><b>Service</b></p> <p><b>Quicklight</b></p> <p><b>Help</b></p>	<p>..... Control .....</p> <p>► <b>Protocol</b> <span style="float: right;"><b>WDMX</b></span></p> <p><b>DMX Address</b></p> <p><b>DMX Mode</b></p> <p><b>Receive</b></p> <p><b>W-DMX Standard</b></p> <p><b>DMX XLR Out</b></p> <div style="border: 1px solid black; padding: 2px; width: fit-content; margin: 5px auto;"> <p><b>DMX</b></p> <p>► <b>WDMX</b></p> <p><b>ArtNet</b></p> <p><b>sACN</b></p> <p><b>Slave</b></p> <p><b>Static</b></p> </div>	<p>..... Control .....</p> <p><b>Protocol</b> <span style="float: right;"><b>WDMX</b></span></p> <p>► <b>DMX Address</b> <span style="float: right;"><b>001</b></span></p> <p><b>DMX Mode</b> <span style="float: right;"><b>36ch</b></span></p> <p><b>Receive</b> <span style="float: right;"><b>On</b></span></p>
---	--	---

See the table below for information on the sub-menu items in the W-DMX menu and the relevant setting options.

Protocol WDMX		
Select by turning the encoder, confirm by pressing, change value or status by turning, confirm by pressing. Back with BACK.		
DMX Address	Setting the DMX start address	001–512
DMX Mode	Selecting the DMX mode	29ch/36ch
Receive	Activate (On) and deactivate (Off) W-DMX	On
		Off
	Reset = Terminate the connection to all paired W-DMX transmitters and put them on pairing standby	Reset

### OPERATION VIA ART-NET PROTOCOL

Starting from the main display, press the rotary-push encoder to enter the main menu. Select the **Control** menu by turning and pressing the encoder. By turning the encoder you can now select the menu item **Protocol**, confirm by pressing the encoder and then select **ArtNet** by turning the encoder and confirm by pressing the encoder.

<p>..... <b>Menu</b> .....</p> <p>► <b>Control</b></p> <p><b>Settings</b></p> <p><b>Info</b></p> <p><b>Service</b></p> <p><b>Quicklight</b></p> <p><b>Help</b></p>	<p>..... <b>Control</b> .....</p> <p>► <b>Protocol</b>                      <b>ArtNet</b></p> <p><b>DMX Address</b></p> <p><b>DMX Mode</b></p> <p><b>Universe Group</b></p> <p><b>Universe</b></p> <p><b>IP Address</b></p> <p><b>Subnet Mask</b></p> <p><b>W-Transmitter</b></p> <p><b>W-DMX Standard</b></p> <p><b>DMX XLR Out</b></p> <div style="border: 1px solid black; padding: 2px; display: inline-block; margin-left: 20px;"> <p><b>DMX</b></p> <p><b>WDMX</b></p> <p>► <b>ArtNet</b></p> <p><b>sACN</b></p> <p><b>Slave</b></p> <p><b>Static</b></p> </div>	<p>..... <b>Control</b> .....</p> <p><b>Protocol</b>                      <b>ArtNet</b></p> <p>► <b>DMX Address</b>                      <b>001</b></p> <p><b>DMX Mode</b>                      <b>36ch</b></p> <p><b>Universe Group</b>                      <b>000</b></p> <p><b>Universe</b>                      <b>000</b></p> <p><b>IP Address</b></p> <p><b>Subnet Mask</b></p> <p><b>W-Transmitter</b>                      <b>On</b></p> <p><b>W-DMX Standard</b>                      <b>G4s</b></p> <p><b>DMX XLR Out</b>                      <b>On</b></p>
--	--	---

See the table below for information on the sub-menu items in the W-DMX menu and the relevant setting options.

Protocol Art-Net		
Select by turning the encoder, confirm by pressing, change value or status by turning, confirm by pressing. Back with BACK.		
DMX Address	Setting the DMX start address	001–512
DMX Mode	Selecting the DMX mode	29ch/36ch
Universe Group	Setting the Universe Group	000–127
Universe	Setting the universe	000–255
IP Address	Setting the IP address: 1. Set block, confirm, set 2nd block, confirm ...	xxx.xxx.xxx.xxx
Subnet Mask	Adjustment of the subnet mask: 1. Set block, confirm, set 2nd block, confirm ...	xxx.xxx.xxx.xxx
W transmitter	Activate (On) or deactivate (Off) forwarding of the DMX signal via W-DMX	On
		Off
	Establish (Linking) or release (Unlink) a connection to other W-DMX devices.	Linking
		Unlink
W-DMX standard	Setting the W-DMX standard (G3 / G4s)	G3
		G4s
DMX XLR Out	Forwarding the control signal via XLR Out Activate (On) and Deactivate (Off)	On
		Off

## OPERATION VIA SACN PROTOCOL

Starting from the main display, press the rotary-push encoder to enter the main menu. Select the **Control** menu by turning and pressing the encoder. By turning the encoder you can now select the menu item **Protocol**, confirm by pressing the encoder and then select **sACN** by turning the encoder and confirm by pressing the encoder.

Menu
▶ <b>Control</b>
Settings
Info
Service
Quicklight
Help

Control	
▶ <b>Protocol</b> <span style="float: right;"><b>sACN</b></span>	
DMX Address	<b>DMX</b> <b>WDMX</b> <b>ArtNet</b> ▶ <b>sACN</b> <b>Slave</b> <b>Static</b>
DMX Mode	
Universe Group	
Universe	
IP Address	
Subnet Mask	
W-Transmitter	
W-DMX Standard	
DMX XLR Out	

Control	sACN
▶ <b>Protocol</b>	
▶ <b>DMX Address</b>	<b>001</b>
<b>DMX Mode</b>	<b>36ch</b>
<b>Universe Group</b>	<b>000</b>
<b>Universe</b>	<b>001</b>
<b>IP Address</b>	
<b>Subnet Mask</b>	
<b>W-Transmitter</b>	<b>On</b>
<b>W-DMX Standard</b>	<b>G4s</b>
<b>DMX XLR Out</b>	<b>On</b>

Information on the sub-menu items in the sACN menu and the relevant setting options is to be found in the table below.

Protocol sACN		
Select by turning the encoder, confirm by pressing, change value or status by turning, confirm by pressing. Back with BACK.		
DMX Address	Setting the DMX start address	001-512
DMX Mode	Selecting the DMX mode	29ch/36ch
Universe Group	Setting the Universe Group	000-255
Universe	Setting the universe	001-256
IP Address	Setting the IP address: 1. Set block, confirm, set 2nd block, confirm ...	xxx.xxx.xxx.xxx
Subnet Mask	Adjustment of the subnet mask: 1. Set block, confirm, set 2nd block, confirm ...	xxx.xxx.xxx.xxx
W transmitter	Activate (On) or deactivate (Off) forwarding of the DMX signal via W-DMX	On
		Off
	Establish (Linking) or release (Unlink) a connection to other W-DMX devices.	Linking
		Unlink
W-DMX standard	Setting the W-DMX standard (G3 / G4s)	G3
		G4s
DMX XLR Out	Forwarding the control signal via XLR Out Activate (On) and Deactivate (Off)	On
		Off

## SLAVE MODE

Starting from the main display, press the rotary-push encoder to enter the main menu. Select the **Control** menu by turning and pressing the encoder. By turning the encoder, select the menu item **Protocol**, confirm by pressing the encoder and then select **Slave** by turning the encoder and confirm by pressing the encoder. Connect the slave and the master unit (same model, same software version) with a DMX cable (Master DMX OUT – Slave DMX IN) and enable the standalone mode Static on the master unit. The slave unit will now follow the master unit.

Menu
▶ <b>Control</b>
Settings
Info
Service
Quicklight
Help

Control	
▶ <b>Protocol</b> <span style="float: right;"><b>Slave</b></span>	
	<b>DMX</b> <b>WDMX</b> <b>ArtNet</b> <b>sACN</b> ▶ <b>Slave</b> <b>Static</b>

Control	Slave
▶ <b>Protocol</b>	

## STANDALONE OPERATION STATIC

Starting from the main display, press the rotary-push encoder to enter the main menu. Select the **Control** menu by turning and pressing the

encoder. By turning the encoder you can now select the menu item **Protocol**, confirm by pressing the encoder and then select **Static** by turning the encoder and confirm by pressing the encoder.

Menu
▶ <b>Control</b>
<b>Settings</b>
<b>Info</b>
<b>Service</b>
<b>Quicklight</b>
<b>Help</b>

Control
▶ <b>Protocol</b>
<b>Static</b>
<b>Run Scene</b>
<b>Record Scene</b>
<b>Edit Scene</b>
<b>DMX</b>
<b>WDMX</b>
<b>ArtNet</b>
<b>sACN</b>
<b>Slave</b>
▶ <b>Static</b>

Control	
<b>Protocol</b>	<b>Static</b>
▶ <b>Run Scene</b>	<b>1</b>
<b>Record Scene</b>	
<b>Edit Scene</b>	

Information on the sub-menu items in the Static menu and the relevant setting options are to be found in the tables below.

Protocol Static	Select by turning, confirm by pressing, change value by turning, confirm by pressing. Back with BACK.	
Run Scene	Scene selection	1 – 8
Record Scene	Record scene (activate DMX, W-DMX, Art-Net, or sACN mode, make desired setting in the relevant controller, select and confirm desired scene)	1 – 8
Edit Scene	Editing a scene	1 – 8

Edit Scene	Select by turning, confirm by pressing, change value by turning, confirm by pressing. Back with BACK.	
Pan	Pan setting	000–255
Tilt	Tilt adjustment	000–255
Dimmer	Brightness	000–255
Strobe	Strobe	000–255
Cyan	CMY color mix	000–255
Magenta		000–255
Yellow		000–255
High CRI	High CRI filter	000–255
Split color	Color screen	000–255
Color wheel	Color wheel	000–255
Gobo	Rotating gobos	000–255
Gobo rot.	Gobo rotation	000–255
Gobo2	Static gobos	000–255
Zoom	Zoom	000–255
Focus	Focus	000–255
Prism1	Prism 1	000–255
Prism1 rot.	Prisma 1 rotation	000–255
Prism2	Prism 2	000–255
Prism2 rot.	Prisma 2 rotation	000–255
Frost1	Frost filter 1	000–255
Frost2	Frost filter 2	000–255
Animation	Animation wheel	000–255
Ani. rot.	Animation wheel rotation	000–255
Pan/tilt macro	Pan/tilt preset	000–255
Pan tilt speed	Pan/tilt speed	000–255

## SYSTEM SETTINGS (Settings)

Starting from the main display, press the rotary-push encoder to enter the main menu. Turn the encoder to select the system **Settings** menu and press the encoder.

----- Menu -----	
<b>Control</b>	
▶ <b>Settings</b>	
<b>Info</b>	
<b>Service</b>	
<b>Quicklight</b>	
<b>Help</b>	

----- Settings -----	
▶ <b>Settings</b>	<b>Lamp</b>
<b>State</b>	
<b>Default</b>	
<b>Mode</b>	
	▶ <b>Lamp</b>
	<b>Display</b>
	<b>Dimmer</b>
	<b>Motor</b>
	<b>Misc</b>

This will take you to the sub-menu for editing the sub-menu items, see table:

<b>Settings</b>			
Select by turning, confirm by pressing, change value or status by turning, confirm by pressing. Back with BACK.			
Lamp	State	Off	Lamp switched off
		On	Lamp switched on
	Default	Off	Lamp switched off after restart
		On	Lamp switched on after restart
		Last	Status before switching off is restored after restart
	Mode	Power	Maximum brightness
Eco		Reduced maximum brightness in the event of reduced fan speed	
Display	Reverse	Off	No display rotation
		On	Rotate display by 180°
		Auto	Automatic display rotation
	Backlight	Off	Deactivation of display illumination after approx. 1 minute without input
		On	Display lighting permanently on
Dimmer	Curve	Linear	Light intensity increases linearly with DMX value
		Exp	Light intensity can be finely adjusted at lower DMX values and broadly adjusted at higher DMX values
		Log	Light intensity can be broadly adjusted at lower DMX values and finely adjusted at higher DMX values
		S-curve	Light intensity can be finely adjusted at lower and higher DMX values and broadly adjusted at medium DMX values

Motor	Pan Reverse	Off	Does not reverse pan direction
		On	Reverses pan direction
	Tilt Reverse	Off	Does not reverse tilt direction
		On	Reverses tilt direction
	Angle	630	630° pan angle
		540	540° pan angle
	Feedback	Off	Automatic position correction is disabled
		On	Automatic position correction is enabled
	Color position	Stand (standard)	Standard rotation of color wheel on color change
		Short	Color wheel turns the shortest distance on color change
	Gobo position	Stand (standard)	Standard rotation of gobo wheel on gobo change
		Short	Gobo wheel turns the shortest distance on gobo change
	Color wheel	Scroll	Color wheel offers continuously variable rotation
		Snap	Color wheel jumps directly back to the desired color filter when the relevant value is reached
	Gobo wheel	Scroll	Gobo wheel offers continuously variable rotation
		Snap	Gobo wheel jumps directly back to the desired gobo when the relevant value is reached
	Blackout P/T	Off	No blackout during head movement
		On	Blackout during head movement
	Blackout Prism	Off	No blackout when value is changed in prism channel
		On	Blackout when value is changed in prism channel
Blackout Gobo	Off	No blackout when value is changed in gobo channel	
	On	Blackout when value is changed in gobo channel	
Blackout Color	Off	No blackout when value is changed in color wheel channel	
	On	Blackout when value is changed in color wheel channel	
Misc.	Auto Lock	Off	Automatic locking of the controls is disabled
		On	Automatic locking of the controls after approximately 1 minute without input. Unlock: Press encoder for approx. 5 seconds
	Signal Fail	Hold	Last command is maintained if the control signal is interrupted
		Scene 1	Scene 1 is activated if the control signal is interrupted
		Fa.out	The spotlight is slowly dimmed down if the control signal is interrupted
		Bla.out	Instant blackout if the control signal is interrupted
	Temp Unit	°C	Displays temperature in Celsius
		°F	Display in Fahrenheit
	Set Def. Values	User A	Save use settings A
		User B	Save user settings B
		User C	Save user settings C

## DIMMER CURVES

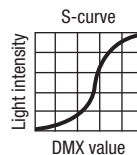
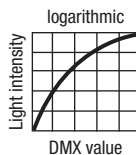
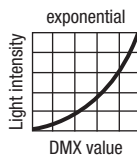
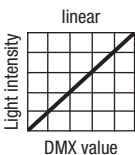



## DEVICE INFORMATION (Info)

Starting from the main display, press the rotary-push encoder to enter the main menu. Turn the encoder to select the **Info** menu for device information and press the encoder. In order to have the required information displayed, select the relevant menu item by turning the encoder and then press the encoder to confirm.

Menu
Control
Settings
► Info
Service
Quicklight
Help

Info	
► Firmware	V1.x.x
Temperature	035°C
Fan Speed	
Runtime	0020 h
MAC	
RDM-UID	
Show DMX Values	
Error Info	
DMX Table	

Info			
Select by turning the encoder, confirm by pressing and return with BACK.			
Firmware	Disp:	V1.x.x	
	NET:	V1.x.x	
	CTR1-Motor:	V1.x.x	
	CTR2-Motor	V1.x.x	
	CTR3-Motor	V1.x.x	
	CTR4-Motor	V1.x.x	
	CTR5-Motor:	V1.x.x	
	CTR6-Motor:	V1.x.x	
Temperature	Head	xxx °C/°F	
	Base	xxx °C/°F	
Fan Speed	BaseFan1	xxxx RPM	
	BaseFan2	xxxx RPM	
	Blower1	xxxx RPM	
	Blower2	xxxx RPM	
	CoolFan	xxxx RPM	
	GoboFan	xxxx RPM	
	LeftFan	xxxx RPM	
	RightFan	xxxx RPM	
	BallastFan1	xxxx RPM	
	BallastFan2	xxxx RPM	
Runtime	Total	xxxx h : xx m	Total operating time
	Lamp	xxxx h : xx m	Lamp operating time
	Service	xxxx h : xx m	Operating time after service appointment
MAC	MAC address		
RDM-UID	RDM Unique Identifier		
Show DMX values	Displays the applied DMX values		
Error info	Error display in case of malfunction		
DMX Table	Display of DMX mode tables		

## SERVICE MENU (Service)

Starting from the main display, press the rotary-push encoder to enter the main menu. Select Quicklight by turning the **Service** encoder and press the encoder to confirm.

Menu
<b>Control</b>
<b>Settings</b>
<b>Info</b>
▶ <b>Service</b>
<b>Quicklight</b>
<b>Help</b>

Service
▶ <b>Default Values</b>
<b>Reset</b>
<b>Test</b>
<b>Reset Service Runtime</b>
<b>Reset Lamp Runtime</b>
<b>USB Update</b>
<b>Password</b>

This takes you to the Service menu, see table:

Service		
Select by turning, confirm by pressing, select command by turning, confirm by pressing. Back with BACK.		
Default values	Factory	Resets to factory setting
	User A	Resets to User A values (save user values: Settings -> Set def. Values)
	User B	Resets to User B values (save user values: Settings -> Set def. Values)
	User C	Resets to User C values (save user values: Settings -> Set def. Values)
Reset	All	Resets all motors
	Pan/Tilt	Resets pan/tilt motors
	Head	Resets motors in the device head
Test	Sequence	Pre-programmed sequence to test all components
	Stress Test	Pre-programmed sequence to test all components under maximum load
	Run Motor	Activate all motors individually with values of 000 to 255
Reset Service Runtime	No	Do not reset service operation time
	Yes	Reset service operation time
Reset Lamp Runtime	No	Do not reset lamp operation time
	Yes	Reset lamp operation time
USB Update	No	Do not run firmware update via USB interface
	Yes	Run firmware update via USB interface
Password	For service purposes only	

## QUICKLIGHT

Set up a scene quickly and easily using the basic Moving Head functions without an external controller. Starting from the main display, press the rotary-push encoder to enter the main menu. Select **Quicklight** by turning the encoder and press the encoder to confirm. Now select the desired menu item again by turning the encoder, pressing the encoder and setting the value from 000 to 255 as desired (change value by turning, confirm by pressing, back with BACK).

----- Menu -----	
<b>Control</b>	
<b>Settings</b>	
<b>Info</b>	
<b>Service</b>	
▶ <b>Quicklight</b>	
<b>Help</b>	

----- Quicklight -----	
▶ <b>Pan</b>	<b>000 - 255</b>
<b>Tilt</b>	<b>000 - 255</b>
<b>Dimmer</b>	<b>000 - 255</b>
<b>Zoom</b>	<b>000 - 255</b>
<b>Focus</b>	<b>000 - 255</b>

If the Quicklight mode is activated, the display does not automatically change to the main display; when leaving the Quicklight menu, Quicklight mode is automatically terminated. The settings in the Quicklight menu are retained until the next restart of the spotlight; as a result, Quicklight can be accessed repeatedly with the same settings as long as the spotlight remains switched on. After restart, the values in the Quicklight settings are reset (PAN = 127, TILT = 127, DIMMER = 000, ZOOM = 127, FOCUS = 127).

## HELP MENU (Help)

In the Help menu you will find three pages with 1. Information on quick commands that take you directly to specific menu items, 2. Information on the division of the display into control panels in the main menu and sub-menus, and 3. Information about the device itself. Starting from the main display, press the rotary-push encoder to enter the main menu. Select **Help** by turning the encoder and press the encoder to confirm. Select the desired information again by turning the encoder.

----- Menu -----	
<b>Control</b>	
<b>Settings</b>	
<b>Info</b>	
<b>Service</b>	
<b>Quicklight</b>	
▶ <b>Help</b>	

----- Help -----	
<b>Shortcuts</b>	
Turn encoder in the home screen to change the DMX address	
Push & turn right to jump to the latest selected menu point	
Push BACK for 3 seconds to jump to the home screen without saving	

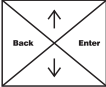
----- Help -----	
<b>Touchscreen</b>	
In home screen: Press left upper corner to jump into main menu or symbols for appropriate point	
In menu: Each area works as button for navigating	
	

	<b>Cameo</b> Opus H5
<small>Cameo® is a brand of the Adam Hall Group www.adamhall.com</small>	

## INSTALLATION AND MOUNTING

Thanks to its integrated rubber feet, the lamp can be positioned in a suitable location on a level surface. Traverse installation can be achieved with the help of two Omega brackets, which are attached to the base of the device **A**. 2 x Omega brackets are included. Suitable beam clamps are available as an option. Ensure firm connections and secure the spotlight to the securing lug with a suitable safety cable **B**.



**Important safety notice:** Overhead mounting, especially above persons, requires extensive experience, including the calculation of the load limit values of the installation material and regular safety inspection of all installation materials and spotlights. If you do not have these qualifications, do not attempt to perform an installation yourself. Refer instead to a qualified professional.

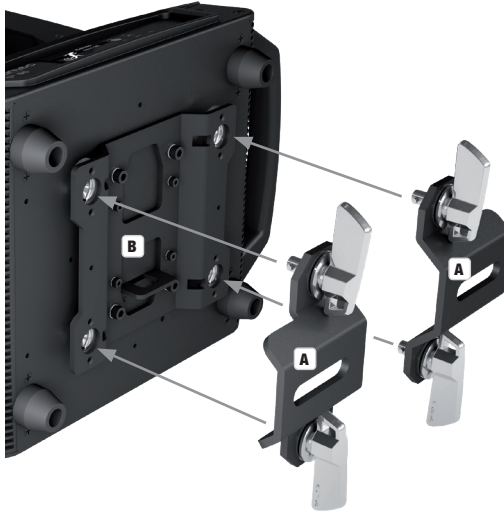

## REPLACING THE LAMP



### Important:

Replacement of the lamp may be carried out by qualified personnel only. If you do not have these qualifications, do not attempt to replace a lamp yourself. Refer instead to a qualified professional.

A hot discharge lamp is under high pressure and can therefore spontaneously explode. Let the lamp cool for at least 30 minutes before opening it.

When replacing light bulbs, use only the model specified in the data sheet.  
Do not touch the glass bulb of the lamp with bare fingers, the lamp must be completely clean.  
When replacing the lamp, wear protective glasses and protective gloves.

**1** Fully disconnect the spotlight from the mains (pull out the plug)!

**2** Loosen the two bayonet screws on the rear head cover (quarter turn counter clockwise) and remove the cover from the spotlight head. In doing so, take care not to damage the cover's protective earth cable.



**3** Disconnect the two cables for power supply to the lamp from the contacts at the connectors.

**4** Press the lamp against the socket and turn it counter clockwise out of the socket (one eighth turn).

**5** The lamp can now be removed from the socket.

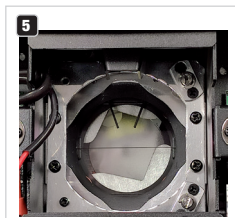
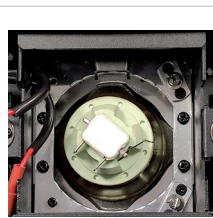
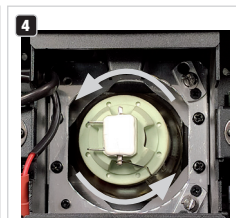
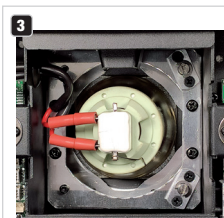

**6** When inserting the new bulb, proceed in reverse order and make sure that the bulb is firmly seated in the socket. Plug the power supply cables back onto the lamp contacts and make sure that they are firmly in place (no polarity reversal possible). Never operate the spotlight without a head cover.

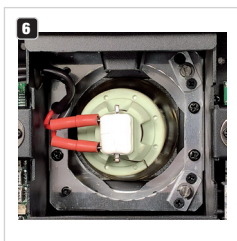

## CALIBRATING THE LAMP



### Important:

Calibration of the lamp may be carried out by qualified personnel only. If you do not have these qualifications, do not attempt to adjust a lamp yourself. Consult a qualified professional instead.

A hot discharge lamp is under high pressure and can therefore spontaneously explode. Let the lamp cool for at least 30 minutes before opening it.

When calibrating the light, use protective glasses and protective gloves and do not operate the spotlight without a head cover.

If the hotspot is not in the centre of the projection of the light beam, it can be calibrated by means of two adjustment screws.

Example:

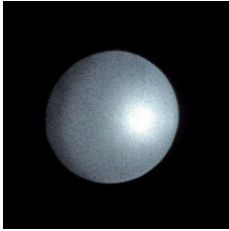

**1** Fully disconnect the spotlight from the mains (pull out the plug)!

**2** Loosen the two bayonet screws on the rear head cover (quarter turn counter clockwise) and remove the cover from the spotlight head. In doing so, take care not to damage the cover's protective earth cable.



**3** Use the two adjustment screws **A** to centre the hotspot (see figure below).

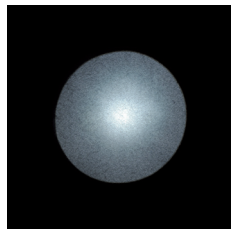
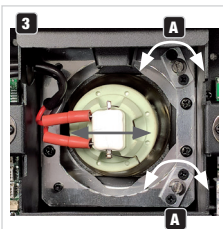

**4** Re-install the head cover securely onto the spotlight head. Never operate the spotlight without a head cover .

## DMX TECHNOLOGY

### DMX-512

DMX (Digital Multiplex) is the designation for a universal transmission protocol for communications between corresponding devices and controllers. A DMX controller sends DMX data to the connected DMX device(s). The DMX data is always transmitted as a serial data stream that is forwarded from one connected device to the next via the "DMX IN" and "DMX OUT" connectors (XLR plug-type connectors) that are found on every DMX-capable device, provided the maximum number of devices does not exceed 32 units. The last device in the chain needs to be equipped with a terminator (terminating resistor).



### DMX CONNECTION

DMX is the common "language" via which a very wide range of types and models of equipment from various manufacturers can be connected with one another and controlled via a central controller, provided that all of the devices and the controller are DMX compatible. For optimum data transmission, it is necessary to keep the connecting cables between the individual devices as short as possible. The order in which the devices are integrated in the DMX network has no influence on the addresses. Thus the device with the DMX address 1 can be located at any position in the (serial) DMX chain: at the beginning, at the end or somewhere in the middle. If the DMX address 1 is assigned to a device, the controller "knows" that it should send all data allocated to address 1 to this device regardless of its position in the DMX network.

### SERIAL CONNECTION OF MULTIPLE LIGHTS

1. Connect the male XLR connector (3-pin or 5-pin) of the DMX cable to the DMX output (female XLR socket) of the first DMX device (e.g. DMX-Controller).
2. Connect the female 3-pin XLR connector of the DMX cable connected to the first projector to the DMX input (male 3-pin socket) of the next DMX device. In the same way, connect the DMX output of this device to the DMX input of the next device and repeat until all devices have been connected. Please note that as a rule, DMX devices are connected in series and connections cannot be shared without active splitters. The maximum number of DMX devices in a DMX chain should not exceed 32 units.

The Adam Hall 3 STAR, 4 STAR, and 5 STAR product ranges include an extensive selection of suitable cables.

### DMX CABLES

When fabricating your own cables, always observe the illustrations on this page. Never connect the shielding of the cable to the ground contact of the plug, and always make certain that the shielding does not come into contact with the housing of the XLR plug. If the shielding is connected to the ground, this can lead to short-circuiting and system malfunctions.

### PIN ASSIGNMENT

DMX cable with 3-pin XLR connectors:

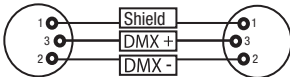

DMX cable with 5-pin XLR connectors (pin 4 and 5 are not used):

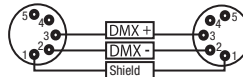

### DMX TERMINATORS (TERMINATING RESISTORS)

To prevent system errors, the last device in a DMX chain needs to be equipped with a terminating resistor (120 ohm, 1/4 Watt).

3-pin XLR connector with a terminating resistor: K3DMXT3

5-pin XLR connector with a terminating resistor: K3DMXT5

### PIN ASSIGNMENT

3-pin XLR connector:

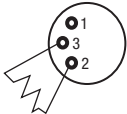

5-pin XLR connector:

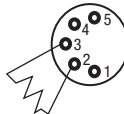

### DMX ADAPTER

The combination of DMX devices with 3-pin connectors and DMX devices with 5-pin connectors in a DMX chain is possible with suitable adapters.

### PIN ASSIGNMENT

DMX Adapter 5-pin XLR male to 3-pin XLR female: K3DGF0020

Pins 4 and 5 are not used.

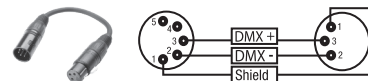

### PIN ASSIGNMENT

DMX Adapter 3-pin XLR male to 5-pin XLR female: K3DHM0020

Pins 4 and 5 are not used.

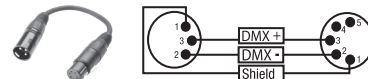

## TECHNICAL DATA

Product number:	CLOH5
Product type:	Discharge Moving Light
Type:	Moving Head
Number of lamps:	1
Type of lamp:	471 W Osram
Color temperature (lamp):	Cool white 7500 K
Color mixing:	CMY
Color reproduction	High CRI Filter >90
Number of colors: color wheel:	13 + open and continuous positioning
Number of gobos:	22 + open (13 fixed + 9 rotating)
Effects:	2x prism levels (1x + 4x), animation wheel, frost filter
Beam angle:	2° - 42°
DMX input:	3-pin XLR male 5-pin XLR male
DMX output:	3-pin XLR female 5-pin XLR female
DMX mode:	29-channel standard, 36-channel extended
DMX functions:	Pan/Tilt, Pan/Tilt Fine, Dimmer, Dimmer Fine, Multifunctional Strobe, Cyan, Cyan Fine, Magenta, Magenta Fine, Yellow, Yellow Fine, High CRI Filter, High CRI Filter Fine, Color Wheel, Color Wheel Rotation, Gobo Wheel 1, Gobo 1 Rotation, Gobo 1 Rotation Fine, Gobo 1 Rotation, Gobo 1 Shake, Gobo Wheel 2, Gobo 2 Shake, Zoom, Zoom Fine, Focus, Focus Fine, Prism 1/2, Prism Rotation, Frost 1/2, Animation Wheel, Pan/Tilt Macros, Pan/Tilt Speed, System Settings
Standalone functions:	Static mode, master/slave operation
System settings:	Display Reverse, Display Illumination On/Off, Signal Fail, Pan Reverse, Tilt Reverse, Pan Angle, Feedback, Movement Blackout, Test, Reset, User Default Values, Blackout Functions, Color/Gobo Wheel Scroll/Snap, Auto Lock, Auto Focus, PWM Frequency, Fan, Motor Speed, Lamp On/Off, Lamp Default, Lamp Mode
Control:	DMX512, RDM enabled, W-DMX™ (Transceiver), Art-Net, sACN
Operating controls:	Encoder wheel + back button / touchscreen
Display elements:	Illuminated color LC display, battery-powered for mains-independent system settings
Operating voltage:	100–240 V AC/50–60 Hz
Power consumption:	700 W
Luminous flux spotlight / lamp:	16000 lm / min. 21500 lm
Power supply connection:	Neutrik powerCON TRUE1 input and output (output max. 6A)
Fuse:	T8AL / 250 V (5 x 20 mm)
Ambient operating temperature:	0–40 °C
Relative air humidity:	< 80%, non-condensing
Housing material:	Metal, ABS
Housing color:	Black
Housing cooling:	Temperature-controlled fan
Minimum distance to illuminated surface:	18 m
Minimum distance to normal flammable materials:	1 m
Dimensions (W x H x D, without bracket):	436 x 662 x 312 mm.
Weight:	27.3 kg
Additional features:	1 m mains cable with Neutrik powerCON TRUE1 connector and 2 Omega mounting brackets included

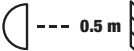

## MINIMUM DISTANCE TO ILLUMINATED SURFACE

 This symbol with distance specification in metres (m) indicates the minimum distance between the light head and the illuminated surface. In this example, the distance is 0.5 m. Please refer to the technical data in this manual and the imprint on the unit casing for the value valid for this unit!

## MINIMUM DISTANCE TO NORMALLY FLAMMABLE MATERIALS

 This symbol with distance specification in metres (m) indicates the minimum distance between the light head and normally flammable materials. In this example, the distance is 0.5 m. Please refer to the technical data in this manual for the value valid for this unit!

## MANUFACTURER'S DECLARATIONS

### MANUFACTURER'S WARRANTY & LIMITATIONS OF LIABILITY

You can find our current warranty conditions and limitations of liability at: [https://cdn-shop.adamhall.com/media/pdf/MANUFACTURERS-DECLARATIONS\\_CAMEO.pdf](https://cdn-shop.adamhall.com/media/pdf/MANUFACTURERS-DECLARATIONS_CAMEO.pdf). To request warranty service for a product, please contact Adam Hall GmbH, Adam-Hall-Str. 1, 61267 Neu Anspach / Email: [Info@adamhall.com](mailto:Info@adamhall.com) / +49 (0)6081 / 9419-0.

### CORRECT DISPOSAL OF THIS PRODUCT

(valid in the European Union and other European countries with a differentiated waste collection system)

■ This symbol on the product, or on its documents indicates that the device may not be treated as household waste. This is to avoid environmental damage or personal injury due to uncontrolled waste disposal. Please dispose of this product separately from other waste and have it recycled to promote sustainable economic activity. Household users should contact either the retailer where they purchased this product, or their local government office, for details on where and how they can recycle this item in an environmentally friendly manner. Business users should contact their supplier and check the terms and conditions of the purchase contract. This product should not be mixed with other commercial waste for disposal.

### FCC STATEMENT

This device complies with Part 15 of the FCC Rules. Operation is subject to the following two conditions:

- (1) This device may not cause harmful interference, and
- (2) This device must accept any interference received, including interference that may cause undesired operation

### CE COMPLIANCE

Adam Hall GmbH states that this product meets the following guidelines (where applicable):

R&TTE (1999/5/EC) or RED (2014/53/EU) from June 2017

Low voltage directive (2014/35/EU)

EMV directive (2014/30/EU)

RoHS (2011/65/EU)

The complete declaration of conformity can be found at [www.adamhall.com](http://www.adamhall.com).

Furthermore, you may also direct your enquiry to [info@adamhall.com](mailto:info@adamhall.com).

## SUBJECT TO MISPRINTS AND ERRORS, AS WELL AS TECHNICAL OR OTHER MODIFICATIONS!



**CAMEOLIGHT.COM**

**Adam Hall GmbH**

Adam-Hall-Str. 1 | 61267 Neu-Anspach | Germany

Phone: +49 6081 9419-0 | [adamhall.com](http://adamhall.com)

Adam Hall Ltd. | The Seedbed Business Centre | SS3 9QY Essex | United Kingdom



REV: 02